

**OB 1**      **Qualifikation FMBB 2023**

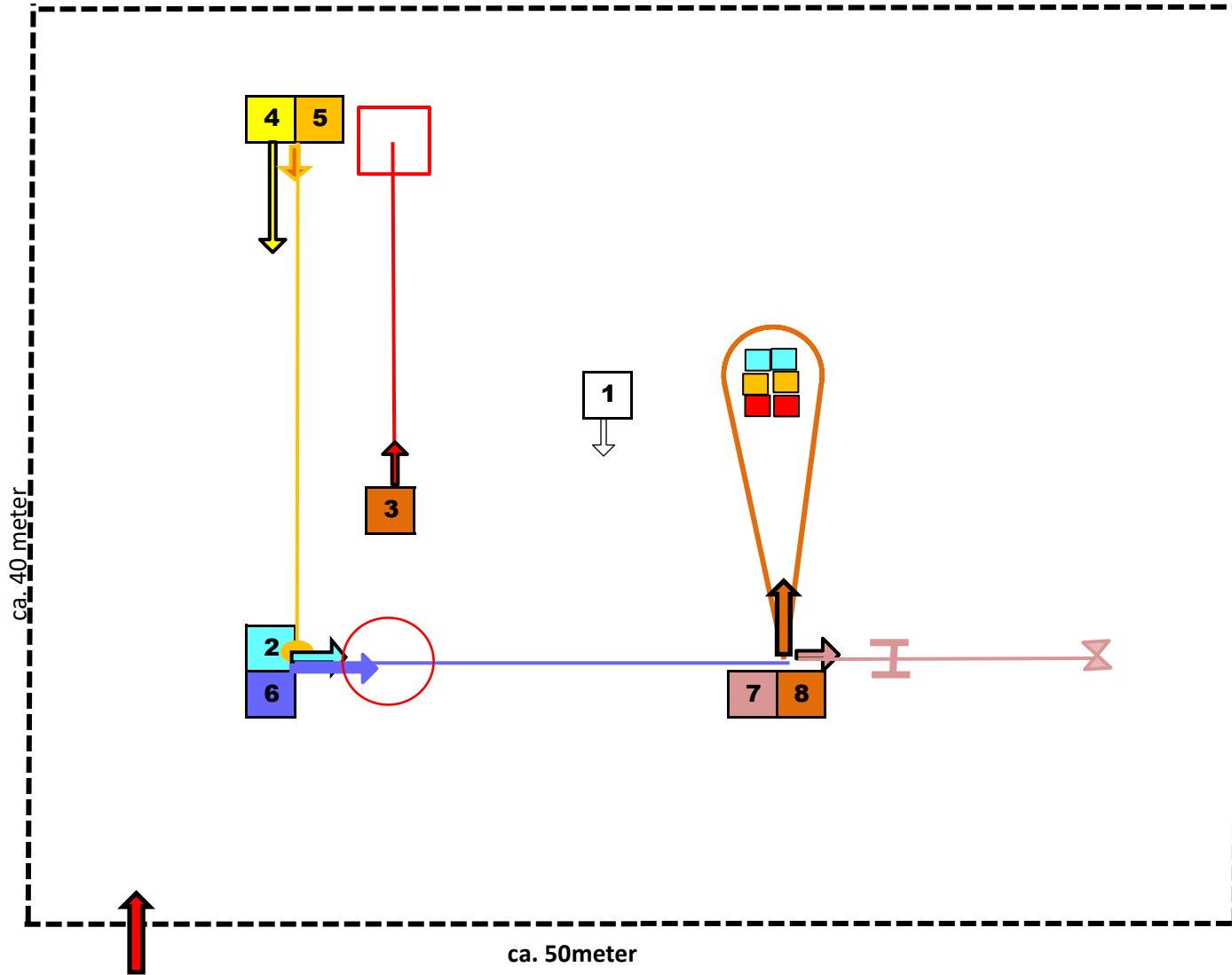

- 1** Sitting in a group
- 2** Heelwork
- 3** Send away, down
- 4** Distance control
- 5** Recall
- 6** Stand or Sit or down under march
- 7** Retrieve over a hurdle
- 8** Send around a group of cones
- 9** general impression

**The exercise starts**

- Normal Pace go
- about turn - stop
- Normal Pace go
- right turn
- left turn
- stop
- left turn normal pace go
- right turn
- Fast pace
- right turn
- right turn
- stop
- 2 steps backwards
- 2 steps forwards
- right turn normal pace go
- about turn
- about turn
- left turn
- stop

**Exercise finished thank you**

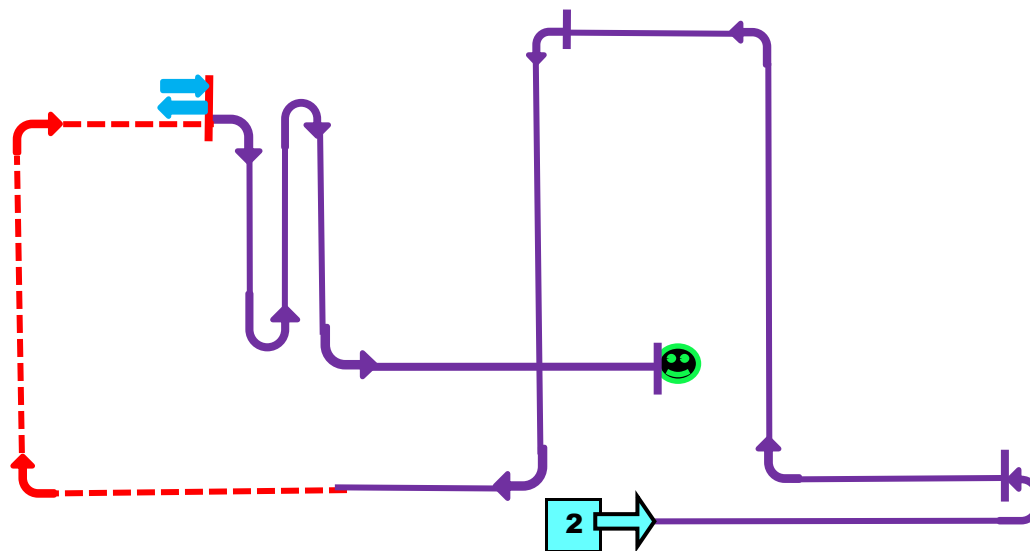

**OB 2**      **Qualifikation FMBB 2023**

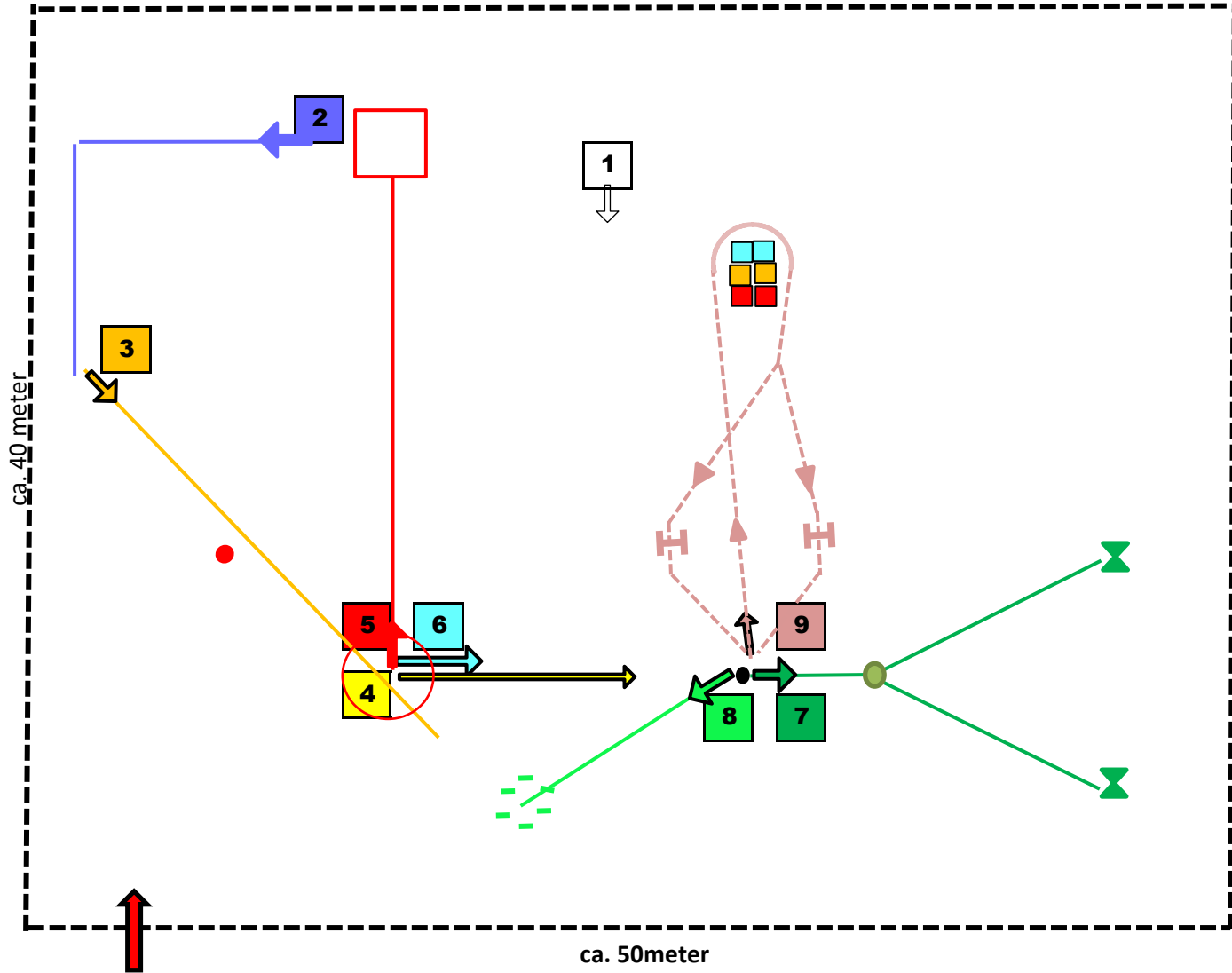

- 1** Laying in a group
- 2** Stand or Sit or down under march (2)
- 3** Recall with stand
- 4** Distant control
- 5** Send away, down + recall
- 6** Heelwork
- 7** directed retrieve left or right
- 8** Scent and retrieve
- 9** Send around a group of cones -stand and jump over a hurdle
- 10** general impression

**FMBB 2023 - OBEDIENCE 2 - Heelwork -Qualifikation**

The exercise starts

Right turn Normal pace go  
about turn  
left turn

Fast pace  
left turn  
right turn  
about turn stop

Backwards go  
stop

Slow pace go  
left turn  
right turn  
about turn  
left turn stop

2 steps forwards  
2 steps backwards

Fast pace go  
right turn  
left turn  
about turn

Slow pace  
right turn

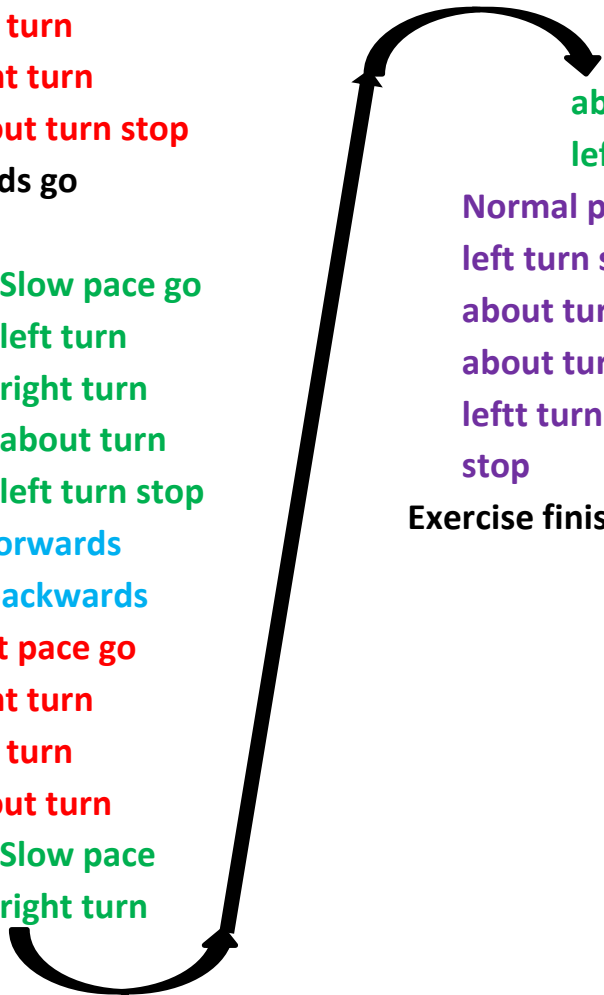

about turn  
left turn

Normal pace  
left turn stop  
about turn normal pace go  
about turn  
left turn  
stop

Exercise finished thank you

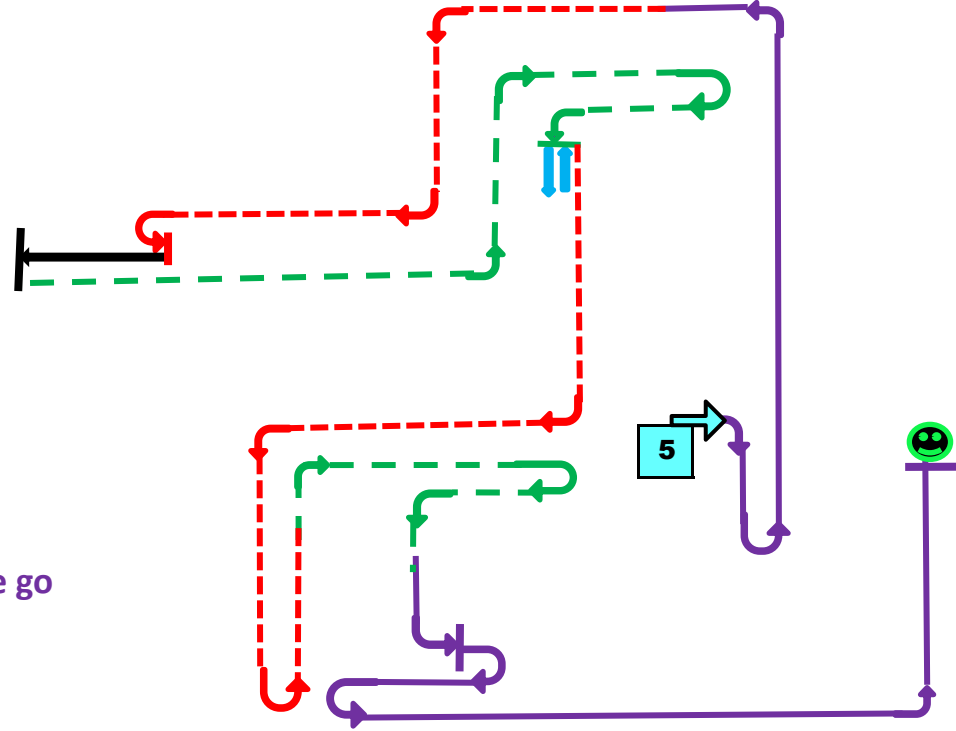

**OB 3**      **Qualifikation FMBB 2023**

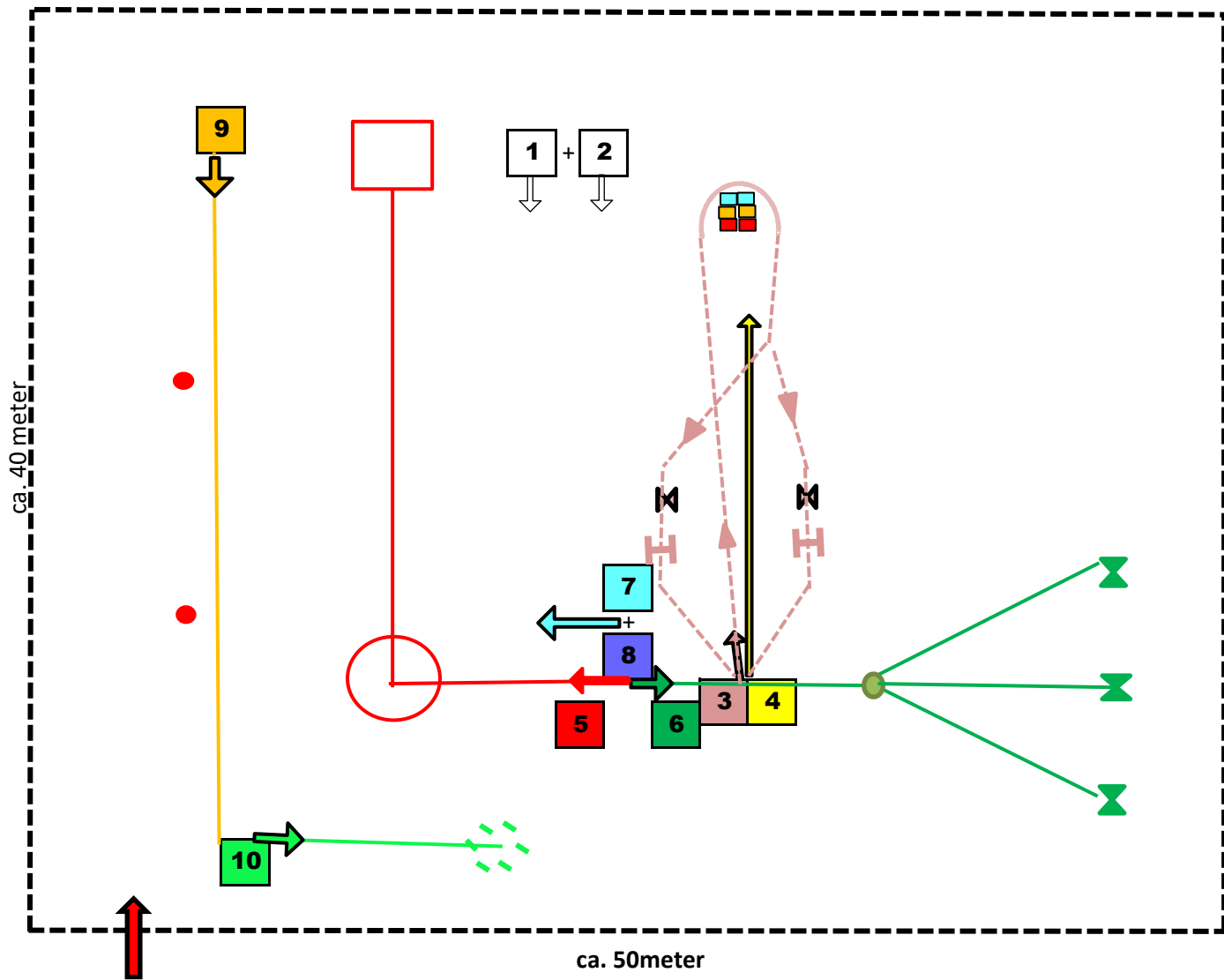

- 1 Sitting in a group
- 2 Laying in a group with recall
- 3 Send around a group of cones  
position and retrieve over a hurdle
- 4 Distant control
- 5 Send away, down + recall
- 6 directed retrieve left/middle/right
- 7 Heelwork
- 8 Stand / Sit / down  
under march (2)
- 9 Recall with stand/sit/down
- 10 Scent and retrieve

The exercise starts

about turn

right turn

right turn normal pace go

left turn

about turn stop

Slow pace go

left turn

about turn

left turn

stop

Backwards go

right turn

stop

Right turn, fast pace go

about turn

left turn

about turn

right turn stop

left turn

3 steps left

3 steps right

About turn, slow pace go

about turn

right turn

right turn

Normal pace

about turn

left turn

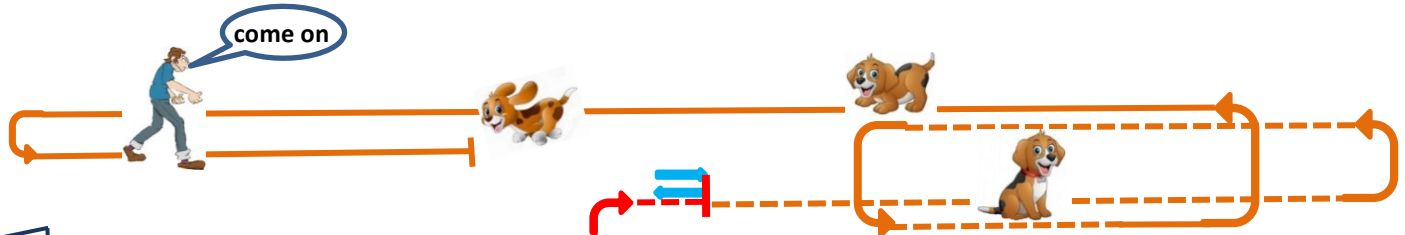

right turn

stop

left turn fast pace go

about turn

right turn

stop

2 steps backwards

2 steps forwards

Heelwork finished

Position under march starts

Position 1 - Sit under march

Fast pace go

Command

about turn

about turn, take your dog

normal pace, 2nd Pos - down with recall

about turn

Command

about turn

call your dog

stop

Exercise finished - thank you

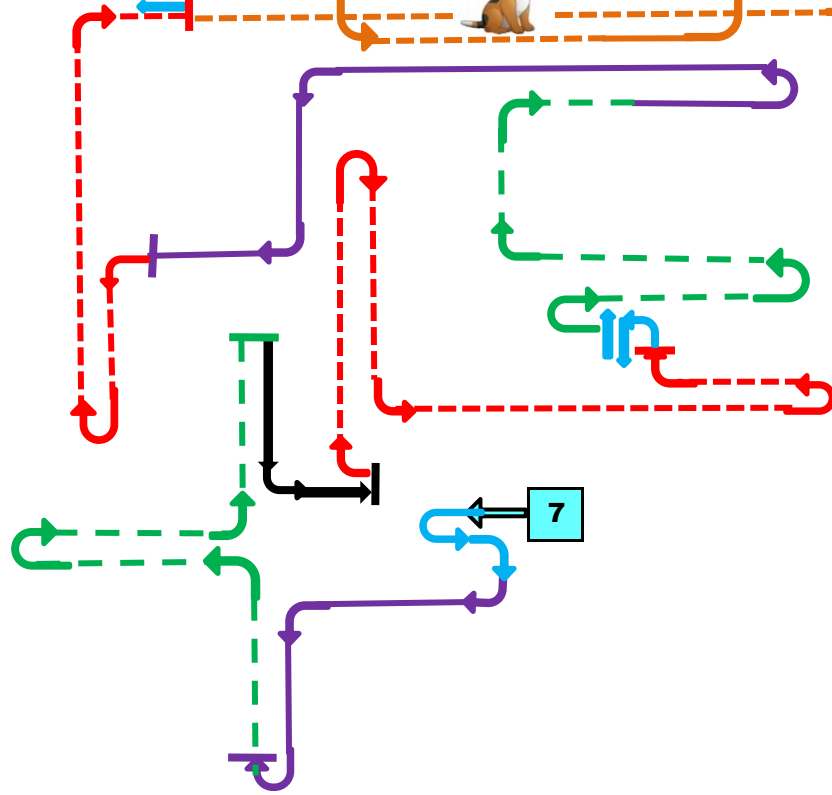

7